



**Metrologic**  
We really work for you.™

MS2220  
compact scanner/scale

## MS200 Series **StratosS™**

**StratosS™** is a high throughput, slim line, bioptic scanner/scale for seated and space constrained checkout environments. The patented modular design provides ease of set up and quick maintenance, ensuring minimum down time and maximum customer service.

StratosS is Metrologic's newest addition to the flagship Stratos® family of bioptic scanner/scales. Its compact form factor, including a 100 mm (4") below counter depth, is designed to allow easy integration into most of today's seated and standing checkout environments. StratosS is a 5-sided, 360° in counter scanner/scale incorporating Stratos advanced scanning architecture and Stratos**SPHERE™** decoding software providing high throughput scanning with minimal need for product orientation.

StratosS comes equipped with Stratos**SCOPE™**, a visual diagnostic indicator providing immediate feedback on scanner condition and a Checkpoint®

compatible EAS deactivation antenna for simultaneous EAS security tag deactivation and bar code scanning. Stratos**SCHOOL™** operator training software allows operators to improve scanning technique allowing for greater productivity and safer scanning methods.

For checkout weighing, StratosS offers a compact fully integrated scale for fast and accurate weighing. The StratosS series of scanners are scale ready allowing for quick and easy field integration of any compatible factory set scale system. We call this feature Stratos**SCALE™**.

Additionally, StratosS offers powered RS232 auxiliary port for integration of a hand held bar code scanner and flash ROM upgrade capability as standard features.

[www.metrologic.com](http://www.metrologic.com)



### FEATURES

- 5-sided, 360° scanning
- Multiple interface
- Stratos**SYNC™** vertical and horizontal scanning zones
- Stratos**SCHOOL™** operator training software
- Stratos**SWAP™** field replaceable optical scanning modules

### BENEFITS

- Reduces product orientation thus increasing productivity and operator ergonomics
- Allows for quick and easy migration to a new host type or interface thus protecting your investment
- Maintains productivity and uptime via independent scanning zones
- Improves productivity and promotes safer scanning techniques
- Minimizes down time and lowers the cost of service

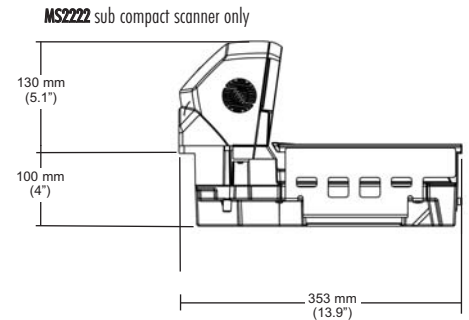
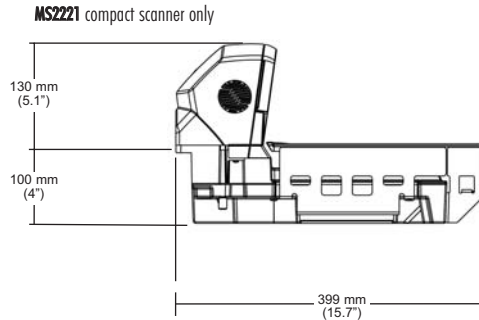
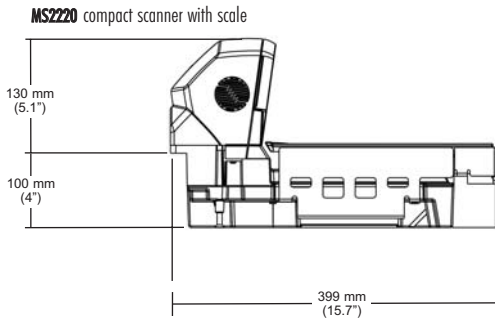

OPERATIONAL	
Light Source	Visible Laser Diode 650 nm ± 10 nm
Laser Power - (horz/vert)	1 mW / 1 mW
Motor Speed - (horz/vert)	6000 / 6000 RPM
Sides Read	5
Decode Capability	All standard 1-D bar codes, RSS-14, RSS-Expanded, RSS-14 Limited
System Interfaces	RS-232, Aux. RS-232, IBM468x/469x, USB, OCIA
Number Characters Read	Up to 80 data characters
Speaker Operation	7 tones or no beep; 3 volume settings
Indicators (LED)	Blue = laser on, ready to scan; White = good read, decoding

MECHANICAL			
Length	MS2220 (compact scanner with scale)	399 mm (15.7")	
	MS2221 (compact scanner only)	399 mm (15.7")	
	MS2222 (sub compact scanner only)	353 mm (13.9")	
Width		292 mm (11.5")	
Depth (below counter)		100 mm (4")	
Height (above counter)		130 mm (5.1")	
Weight	MS2220 (compact scanner with scale)	9.97 kg (22 lbs)	
	MS2221 (compact scanner only)	7.20 kg (16 lbs)	
	MS2222 (sub compact scanner only)	6.80 kg (15 lbs)	

SCALE CHARACTERISTICS	
Capacity	15 kg (30 lb)
Minimum increment	0.005 kg (0.01 lb)
Maximum static weight	68 kg (150 lb)
Adjustments required	Field calibration if necessary
Applications	Weigh-only and price computing
Scale partners	Avery Weigh-Tronix®, Bizerba®, Dibal® and Mettler Toledo®

ELECTRICAL	
Input Voltage	5 V @ 2 Amps / 12 V @ 1 Amp
Power	13.5 W (when scanning); 5 W (standby)
Operating Current	900 mA (5V) / 700 mA (12V)
DC Transformers	Class 1; 5 VDC @ 1.5 A; 12 VDC @ 1.5 A
Laser Class	CDRH & IEC: CLASS 1 LASER PRODUCT according to IEC 60825-1:1993+A1:1997+A2:2001
EMC	FCC, ICES-003 & EN55022 Class A

ENVIRONMENTAL	
Operating Temperature	0°C to 40°C (32°F to 104°F)
Storage Temperature	-40°C to 60°C (-40°F to 140°F)
Humidity	5% to 95% relative humidity, non-condensing
IP Rating	IP 55
Light Levels	4842 Lux (450 footcandles)
Contaminants	Sealed to resist airborne particulate contaminants
Ventilation	None required

SCAN PERFORMANCE	
Depth of Scan Field - (horz)	0 mm - 100 mm (0" - 4") for 0.33 mm (13 mil) bar code
Depth of Scan Field - (vert)	0 mm - 216 mm (0" - 8.5") for 0.33 mm (13 mil) bar code
Scan Speed	5400 scan lines per second
No. of scan lines - (horz/vert)	54 (38 / 16)
Scan Zone	360°
Minimum Bar Width	0.127 mm (5 mil)
Print Contrast	35% minimum reflectance difference
Roll, Pitch, Yaw	360°, 60°, 60°

**ALL MODELS**

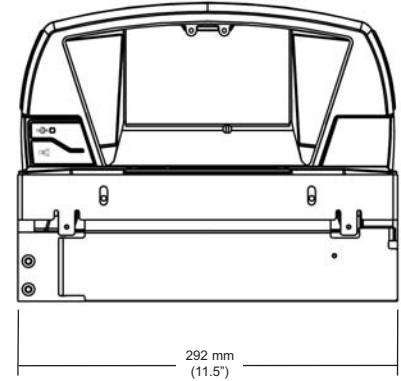

Product Colors Available

Dark Grey Black

MS222X is available in a variety of other colors with minimum quantity purchase



Metrologic Instruments, Inc. | **Worldwide Headquarters**  
 90 Coles Road | Blackwood, NJ 08012-4683 | www.metrologic.com  
 Telephone 856-228-8100 | Fax 856-228-6673 | info@metrologic.com

**Asian Headquarters** Tel. 65.6842.7155 info@sg.metrologic.com  
**European Headquarters** Tel. 49.89.89019.0 info@eu.metrologic.com  
**The Americas Headquarters** Tel. 1.800.ID.METRO info@us.metrologic.com

Specifications subject to change without notice.  
 Printed U.S.A., Copyright January 2006  
 Metrologic, All rights reserved.



DS2200

ISO 9001:2000